

BUSINESS NAME AND MAILING ADDRESSES

FASTRAK Racing Series

Corporate Office

Mailing: PO Box 590

Shipping: 8077 Royston Rd.

Carnesville, GA 30521

Office: (678) 935-7304 Fax: (678) 528-3117

Founder: R. Stan Lester

President: Mary Kay Combes

GM/Press: Michael Hurley

Points: Michael Hurley

Tires: Ashley Milford

Accounting: Ashley Milford

Tech Director: Rick Ellison-Shane Hayes

Regions: Go to www.fastrakracing.com

WEB SITE

www.fastrakracing.com

TECHNICAL UPDATES

Please make sure we have your email address for updates. WE DO NOT SEND ANYTHING VIA THE U.S. POST OFFICE. If you do not have email, please let us know of someone we can forward the updates too.

MEMBERSHIP FEES

2010 membership fees: YOU MUST BE A MEMBER TO RECEIVE POINTS. POINTS ARE NOT 'RETROACTIVE'. YOU WILL NOT RECEIVE POINTS UNTIL MEMBERSHIP HAS BEEN PAID. If membership is paid 'after' event, that event does not count towards points.

National Weekly Championship: \$10,000 to win and pays through 50 positions. \$100 MEMBERSHIP Points start first weekend in April and end the last weekend in September.

Regional Touring Championships: Point fund amounts vary from Region to Region. Contact your regional director. \$100 MEMBERSHIP. Points start pertaining to each individual region. Must run 75% of races to receive point money per region.

Grand National Championship: \$30,000 to win and pays through 24 positions for 3 nights of racing at year end. Membership included with either or both, Regional Touring membership or Weekly membership. Must meet minimum race requirements to attend this event. Minimum race events for eligibility may be through either weekly, regional touring or a combination of both. Must be a member of both to receive points for both, and/or minimum number of race events for Grand National's eligibility. (12 races to qualify for Grand Nationals).

**FASTRAK reserves the right to amend the Grand Nationals based on economic conditions.

YOU MAY BE REQUIRED TO SHOW MEMBERSHIP CARDS AT EVENTS. KEEP THEM WITH YOU AT ALL TIMES.

HOW THE CHAMPIONSHIP AND POINT SYSTEMS WORK (detailed explanation)

***Hoosier/FASTRAK SPEC TIRES MUST BE PURCHASED THROUGH FASTRAK 'AUTHORIZED' TIRE DEALERS FOR ELIGIBILITY TO COMPETE FOR POINTS.** List on www.fastrakracing.com FT200, FT400, FT600 crate spec.

NATIONAL WEEKLY RACING SERIES Corporate Office pays the WEEKLY RACING SERIES POINT FUND.

*Must be a member and pay \$100 MEMBERSHIP

*Can race at any FASTRAK weekly sanctioned track in the United States and receive points.

*Best 15 finishes. Run as much as you would like.

*If you come to a touring event, it may be counted towards your 'weekly points'.

Point system:

1)35, 2)34, 3)33, 4)32, 5)31, 6)30, 7)29, 8)28, 9)27, 10)26, 11)25, 12)24, 13)23, 14)22, 15)21, 16)20, 17)19, 18)18, 19)17, 20)16, 21)15, 22)14, 23)13, 24)12. (11 points for cars not making the main or having mechanical problems during racing under a "competition green". Does not include practice sessions).

Bonus Points (weekly championship only) based on car count: Everyone signed in for the event and making an attempt to start. (Must take at least one green flag lap under competition to receive bonus points). Maximum bonus points 12. Does not include practice sessions.

Example: 5 cars- 5 bonus points to everyone. 10 cars- 10 bonus points, 12 cars – 12 bonus points, 20 cars- 12 bonus points. MAXIMUM BONUS POINTS 12.

Ties will be broken by 1st place finishes then 2nd place finishes and so forth until tie is broken. Ties will be based on ALL finishes not just the best 15. Should tie breaker not be possible, we combine the money amounts and split them equally among those competitors. Points start 1st weekend in April through last weekend in September

REGIONAL TOURING SERIES Each region is responsible for their own Regional Points Fund. Must be a member of FASTRAK Touring Region to receive points and pay \$100 MEMBERSHIP. Points count towards your respective region.

Touring events use the Hoosier/FASTRAK FT200, FT400, FT600 (right rear option) compounds.

Point system is the same as above, 35, 34 and so forth. Points include ALL races in the region you are registered.

No bonus points in Regional Touring Series.

Ties will be determined as above in weekly racing series.

Must run 75% of Touring events in your area to be eligible for any Regional point money.

Corporate Office is not responsible for, but will work on drivers behalf should Region 'Licensee' not pay point fund.

National events: National events are designated on schedule with purses of \$5000 to win or more. Could be counted towards weekly points and respective regions. (Call your Regional director)

GRAND NATIONALS Grand National Point fund is paid by Corporate Office.

Must be a member of FASTRAK BEFORE races are counted towards minimum race requirements.

Must run a minimum of 12 events (weekly, regional or combination of) to be eligible for Grand Nationals.

Must be a member of both Weekly and Touring to count **both** towards eligibility.

Number of races may vary on a region by region basis for *unforeseen circumstances*. (Such as inclement weather, etc).

Ties in Grand National Points: Point fund amounts will be added together for those positions, then split equally among those competitors.

Everyone starts with 0 points.

Every region holds their own "night 1". (some regions may be combined)

All teams come together and race for nights 2 and 3.

Total of points in the 3 events determines positions.

Grand National point checks will be awarded at year ending Regional Banquets

Checks will be mailed via "certified mail" the following week should team not attend points banquet.

**FASTRAK reserves the right to 'amend' Grand National Championship based on economic conditions.

ALL RULES ARE AT THE DISCRETION OF SERIES OFFICIALS

Series Officials reserve the right to change, delete or amend the rules in the interest of "competition".

Weekly Sanctioned tracks MUST run by FASTRAK rules unless track has attained "amendment" from Corporate Office.

Touring Regions must run by FASTRAK rule book.

The Series is not responsible for payment of the purse. In the event of any payment problem at a track, the Series will attempt to resolve the problem on behalf of the drivers.

**Governed by "spirit and intent of the rules".

ENGINES

GM 602 Car and Driver: 2250 lbs (Touring events allow 1 lb per lap 'burn off' in *feature only*)

GM 604 Car and Driver: 2400 lbs (Touring events allow 1 lb per lap 'burn off' in *feature only*)

All Engines and parts must be *as from factory* and all components thereof. THIS MEANS ALL!

The ONLY time a change can be made is with a letter of approval from FASTRAK Corporate Office.

Any "unauthorized" changes will result in disqualification, no points, fines and other possible penalties including but not limited to being barred.

This includes, but is not limited to, harmonic balancers, valve springs, push rods, rocker arms, and after market valve

***NO upgrades are allowed to any engine that may produce power via "performance enhancing methods". This includes any "breather system" modification.

Only FASTRAK "authorized" engine builders have FASTRAK engine seals.

**Must be a member of FASTRAK to receive FASTRAK engine seals.

IF YOU ARE CAUGHT CHEATING “WITHIN THE BOLTS”

(THIS INCLUDES “AFTERMARKET” VALVE SPRINGS)

Driver is fined \$1000 and barred for 365 days

Loss of points

Cannot compete in GRAND NATIONALS

If car owner is ‘separate’ of driver, car owner will be under the same penalty.

Neither driver or car owner (if separate) may compete at any FASTRAK weekly sanctioned track and or touring event for 365 days.

Track event: (Track receives 50% of \$1000 fine)

Regional Touring event: (Region receives 50% of fine)

EXCEPTION: If FASTRAK “authorized” engine builder signs legal “affidavit” stating that competitor had NO knowledge of rules infraction in relation to building of ‘said’ engine

Competitor and/or car owner (if separate) will be fined \$500.

Competitor and/or car owner (if separate) will be suspended for 30 days

Competitor and/or car owner (if separate) will lose all points.

***ALL RULES in effect for ALL OPEN SHOWS that are FASTRAK Sanctioned.**

***By participating in ANY FASTRAK event (Touring, Weekly or Open) Competitor, Owner and any affiliates of such agree to a “hold harmless” agreement under the terms of this rule book.**

Competitors, Car Owners, Engine Builders have the right to “appeal” at the FASTRAK Corporate Office. Findings at said appeal shall be binding and FINAL! Appeals must be filed in writing within 48 hours of infraction. Appeals may be faxed to: (678) 528-3117.

GM ‘RM BOLTS’ WILL NOT BE LEGAL IN 2011

PROTESTS

Top 5 cars can protest anyone within top 5 positions.

Engine CLAIM RULE:

GM 602 HP \$3500 Claim

GM 604 HP \$5500 Claim

Participant refusing to allow claim will be **considered** ‘illegal within the bolts’ and penalties according to such will apply.

Tear Down Rules: All fees must be paid in full within 10 minutes of protested car crossing scales. Protestor must have money in hand for protest. ONCE PROTEST IS DECLARED, IT CANNOT BE WITHDRAWN!

COMPLETE TEAR DOWN: \$800.00 fee. \$200.00 goes to series and/or track (engine will be put back together at FASTRAK “authorized” engine builder for \$600 plus any applicable parts. NOTE: \$600 is for reassembly and re-sealing. Does NOT include any additional needed parts related to wear and tear).

CAM PROFILE: \$300. \$100 goes to Series and/or track.

PULL HEAD AND INTAKE: \$300. \$100 of fee goes to Series and/or track.

WEIGH CRANKSHAFT: \$300. \$100 of fee goes to Series and/or track.

*In the case of two day shows, engines will be marked for legality. Marked engine must be present at post race tech. If marked engine is not present, competitor will be disqualified.

*Should competitor change engines, tech personnel must be notified in advance. Both engines may be subject to technical inspection and both must be present for inspection. No advance notification will result in automatic *disqualification*.

FASTRAK RESERVES THE RIGHT TO CHECK ANY COMPETITORS ENGINE BY DYNO TESTING, TEAR DOWN, OR ANY OTHER MEANS FOUND NECESSARY TO CONFIRM THE LEGALITY OF AN ENGINE. Any competitor that will not allow testing procedures per the discretion of the Regional Director, Tech Official or FASTRAK Official, will be considered to be “cheating within the bolts” whereby penalties will apply.

FASTRAK WILL CONTINUE VIGOROUS INVESTIGATION INTO BACKGROUND OF TEAM OWNER, DRIVER, AND ALSO DO INVESTIGATIVE WORK TO FIND ENGINE BUILDER RELATED TO ANY SUCH INCIDENT OF CHEATING.

FASTRAK WILL NOT TOLERATE CHEATING WITHIN THE BOLTS/SEALS. FASTRAK WILL PROSECUTE ENGINE BUILDERS FOUND TO BE CHEATING ENGINES OUTSIDE OF GM TECH MANUAL SPECIFICATIONS. LAW PERTAINS TO "SPIRIT OF COMPETITION". DOING ILLEGAL WORK INSIDE OF A SEALED ENGINE IS IN DIRECT CONFLICT OF ANY SERIES UTILIZING SEALED ENGINES. ENGINE BUILDER WILL BE BARRED FOR LIFE, REPORTED TO GM AND EVERY SERIES AND TRACK IN THE UNITED STATES KNOWN TO FASTRAK. ARTICLES WILL BE PUBLISHED IN MAJOR NEWSPRINT SHOULD SUCH INCIDENT TAKE PLACE. We consider this to be a serious offense and it will be treated as such.

APPEAL PROCESS:

Appeals must be made in writing in the following manner

- 1) For weekly tracks: in writing the same night of said protest to track Official
- 2) Regional Touring events: in writing the same night of said protest to Regional Official
- 3) In both instances copy of APPEAL must be faxed to FASTRAK corporate office within 48 hours of said protest.

APPEAL will be heard by all parties involved plus someone from the FASTRAK Corporate Office and possibly legal counsel of FASTRAK. By becoming a member of FASTRAK, you are agreeing that the decision made by the corporate office will be final and party posting APPEAL has no legal rights thereafter.

CARBURETORS

*Any 750 CFM Carb or smaller. Must have 1 11/16th (standard) base plate maximum. No exceptions

*Billet base plates may be used (.780 maximum)

604 1 Inch carb spacer maximum **(0 TOLERANCE)**

602 2 Inch carb spacer maximum **(0 TOLERANCE)**

***Please take time to check your plate with a gauge, not a tape measure.**

Spacer may not protrude into carb or intake at any point. .

One gasket per surface. .070 maximum.

*No fuel injection, nitrous oxide or other type systems allowed.

*Two throttle springs strongly recommended!!

*Aerosol carbs are not legal.

FUEL SYSTEMS

Mechanical fuel pump only.

NO electric fuel pump of any type

EVACUATION SYSTEMS

EVACUATION SYSTEMS ARE NOT ALLOWED OF ANY TYPE!. Note: This means any type vacuum system.

Includes vacuum from that of breather system and/or any other means of "pressure evacuation".

HEADERS

Tri Y headers are not legal.

No merge collectors

*Please note it has been brought to our attention the use of custom headers. Should the price of headers become what the series considers 'unreasonable' and an unfair advantage, the series retains the right to use 'spec headers'

OIL PUMP

Wet sump only.

No external oil pumps. Even if considered "wet":

Remote oil filter and lines permitted. (One) remote oil filter.

Oil cooler allowed. (One)

DISTRIBUTOR

No magnetos.

Electronic ignition allowed.

MSD type box allowed.

Series retains the right to change MSD boxes at any time without notice.

No crank triggers or devices that allow external adjustment of timing.

ELECTRONIC DEVICES

No electronic devices allowed on any car thereby enhancing adjustment of that car.

Electronic brake "cut off" legal on right front only

No remote control devices allowed on any car during any event.

Lap timers allowed during practice sessions only.

No electronic devices controlling shocks.

Exotic Materials:

ALL exotic materials are illegal. That includes titanium and/or carbon fiber.

**Carbon fiber drive shafts are legal for safety purposes.

TRANSMISSION

In and out box is not permitted

Any transmission without 'exotic materials' allowed. Must have working clutch with forward and reverse gear.

Drive shafts should be painted white with car number. This is a safety issue!!!

Drive shaft loop is highly recommended. This is a safety issue to you and your fellow competitors.

Automatic transmission allowed.

Air shifters not allowed.

Carbon fiber, aluminum or steel drive shafts permitted.

REAR ENDS

Any Standard Quick Change Rear End

No open type (sprint car) rear ends

Traction control not permitted

9 " Ford rear end or similar type rearend not permitted

No titanium moving parts within rear end including wheel studs

BRAKES

All cars must have operational 4 wheel braking systems

Electric or manual proportioning valve permitted

Carbon fiber, titanium or other exotic materials are not legal

WHEELS

Maximum 14 inch wheels permitted

Steel or aluminum only

Bead locks permitted

Carbon fiber or titanium wheels are not legal.

TIRES

Tires must be purchased through an "authorized" FASTRAK tire dealer to be eligible for points.

Hoosier FASTRAK FT200, FT400 or FT600 (right rear only option).

Goodyear G45/G50 allowed at first 4 events only. MAY NOT MIX AND MATCH. One brand or the other.

No grooving or sipeing

Tires may be checked by officials at any time. Must meet minimum durometer requirements.

Tires may be marked at discretion of Series/track. Re: paint marks or other means of identification.

Tires may be confiscated by Series/track at anytime (for checking numbers versus spec altering, etc).

Tires may be checked by independent lab for 'treating' and other alterations.

NO SIPEING. Tire surface must remain as from factory. NO ALTERATIONS.

Mild 'buffing' permitted. Marks that could be considered 'sipeing' are illegal. (Check with tech man first).

Once a competitor is found 'illegal' they are out for that event in its entirety. NO POINTS!, loss of monies including that of ANY Championship monies including Grand National events which could affect point positions.

Any tire by any manufacturer that is found to be a compound other than stamped will be barred from any events now and in the future. Manufacturer will be charged a \$50,000.00 fine!

*FASTRAK reserves the right to alter tire rules from the standpoint of "SAFETY AND LOCAL TIRE RULES"

*FASTRAK reserves the right to alter tire rules in the case of supply issues.

SOFTENING, CONDITIONING, NEEDLING OF TIRES ARE ILLEGAL!

\$10,000.00 fine, loss of points, cannot compete for ANY Championship monies for competitor.

\$10,000.00 fine, loss of points, cannot compete for ANY Championship monies for car owner.

Originating Source of tire treatment WILL BE turned over to Environmental Protection Agency (EPA).

FASTRAK reserves the right to bring in the Environmental Protection Agency (EPA). Competitor and all parties involved may be prosecuted by EPA within Federal Law!

*****All parties agree to a "hold harmless" agreement under the above terms and of ALL FASTRAK rules by participating in or at a FASTRAK event.***

FIREWALL

Must be approved firewall (approved by Series Official)

Edges of firewall should be completely 'sealed' with silicone or similar material in case of fire.
Floor should be reinforced for safety.
Sheet metal beside driver should be strongly reinforced or use heavier gauge in this location.

BODIES (check diagram in rear of rules) *All measurements are with driver 'in the car'**

Ford, GM, Dodge and Toyota bodies allowed.

All body parts must be same as nose. (Ford, GM, Dodge, Toyota)

Standard Dirt type bodies only.

No wedge bodies.

No lips allowed on roof, sides or nose that may be utilized for spoiler purposes. (Inside or outside)

All upper and side panels must run parallel to chassis.

Front fenders and hood must be level and flat from left side to right side of car and at least as far back as engine plate.

No part of fenders or hood may be below outside body line nor angle inward or outward.

A single strip of plastic material along the bottom of doors permitted.

No part of rear deck may extend past quarter panels.

Center of rear hub to end of quarter panel cannot exceed 48 inches. Measured in a horizontal line.

Center of hub measured diagonally to top of rear deck maximum 52"

Must have at least one number on both doors and number on roof pointed towards scorers from back straight.

No part of body may "V in" from outside to middle of car or middle of that part.

No wheel skirts.

37 inches from top of door to ground maximum.

Rear Deck height measured from ground 38 inches maximum with driver in car.

78 inches at the top of the doors maximum. Checked at firewall and behind driver's seat.

72 inches maximum rear width measured at spoiler.

78 inches maximum rear body width measured 12 inches below spoiler.

Maximum width of body measured at bottom of doors 86 inches. Measured in the center of doors.

2 inch body clearance around the tire' for inspection purposes.

ROOFS

Sheet metal, fiberglass or plastic. Carbon fiber edges permitted.

No odd shaped or partial tilted roofs. Must be parallel to body.

Must have roof supports and posts. Bottom of front post Maximum 12 inches. Post must run in straight line and maximum 4 inches total of both sides. May taper at bottom into post.

No V shape of roof measured from outside to middle.

Roof Length Minimum 44 - Maximum 54

Roof Width Minimum 48 - Maximum 52

Quarters windows must be either, both sealed or both open. (If open, cannot be 'offset and must be the same size').

Quarter windows maximum 43 1/2 inches.

Front and rear of roof must roll, not create a spoiler effect.

Rear roof supports cannot be offset. Must meet edge of body. Maximum 3 inch arch measured on front side.

Window openings must be same as body. Re: Ford, Dodge, Chevy, etc

Sail panel must 'taper down' at rear corner of roof.

NOSE PIECES

Any extensions must be of flexible material. Maximum of 2" outside of front tires.

Must be mounted flat to top of fenders. Fenders may not "V" in.

Maximum measured from center of front hub is 54 inches at furthest point.

Nose must be same as body type.

INTERIOR

Interior body work may be dropped a maximum of 4 inches below the door. Drop interior must be enclosed at firewall in case of fire.

Flat interior must maintain a minimum of 11 inches from roll cage to allow for easy exit in emergencies

SPOILERS

8 inch spoiler only

Metal or Lexan permitted. Plexiglas is not permitted.

Adjustable spoiler permitted up and down only. Side to side not permitted. Spoiler may not be adjustable during the race.

Maximum measurement is 8 inches tall X 72 inches wide.

2 piece spoiler allowed but must be bolted together at joint and attached to single blade at that joint.

If bolted together, both pieces must be exact same angle.

Measured total of all material including any turns including support brace.

Spoiler may not extend over side or rear of car.

3 blades allowed. Rear of blade must be even with rear of deck (tolerance for piano hinge only).

Supports or blades maximum length of 18 ½ inches where it attaches to the car. Includes middle blade.
Blade must have a minimum of 2 ½ inches clearance between front of blade and quarter window.
Blade at front edge must be a maximum height of 4 inches.
If angle material is used to support rear of spoiler, it must be mounted at least ½ inch below top edge of spoiler

Cars with GM 602 engine **MAY utilize 12" inch 'side blades'. Middle blade 'if used' must remain 8 inches. Both side blades must be the same size.
*12" inch side blades. Use same pattern as 8" inch blade in diagram. 4 inches front maximum, tapering in a straight line to the rear of blade.

ROLL CAGE

No aluminum or titanium cages permitted.
All tubing must be a minimum of 1 1/2 inches and a minimum of .083 wall thickness.
Three bars in driver's side mandatory, two bars in right side mandatory.
Must have a minimum of 1 inch bar, .083 wall thickness in halo section running either front to rear or diagonal across.

DRIVERS COMPARTMENT/DRIVER SAFETY

Fire suit mandatory. One or two piece.
Racing shoes and gloves mandatory
Seat of racing type design and bolted to frame not floor.
Right side head rest mandatory, left side suggested.
Hans or other type device not mandatory, but *strongly recommended*.
Quick release steering wheel mandatory.
Batteries may not be located inside driver's compartment.
Helmet with fire resistant interior.
Full set of racing seat belts and mounted to frame and not floor mandatory. **NO SEAT BELTS OLDER THAN TWO YEARS!**
Must have working fire system at all times. Not charged means not working. Gauges must be visible.

Mirrors are not allowed.

FUEL CELL

Fuel cell must be mounted behind rear end housing between frame rails in what is known as "industry standard".
Must be securely strapped with minimum of two steel straps. (Other state laws may apply, NJ, etc)
Straps must be 2 inches wide x 1/8 inch thick.
Must be mounted inside fuel cell steel box.
No part of fuel cell may be below bottom of rear housing.

FUEL

Methanol and/or alcohol not allowed.
E-85 Ethanol is legal.
Series retains the right to check fuel at anytime.
Propylene, nitro methane, nitro propane or any cancer causing agents are illegal. Use of propylene, nitro methane, nitro propane or any cancer causing agents will result in a \$1000 FINE

CHASSIS

No part of frame may be aluminum, titanium or other 'exotic' material.
All frames must be a minimum of 2 inches square or rectangular with minimum of .083 wall thickness.
Round tube frames must be a minimum of 1 3/4 inches and a minimum wall thickness of .083. 4130 chrome moly only.
Wheelbase minimum of 103.0 at any time.
Wheel width from side to side is 88 inches maximum. Measured from outside to outside of rear tires.
Wheel spacers permitted.
All lead must be solid blocks. No lead shot permitted.
All lead MUST BE painted white with car number on it. This is a safety issue!
All lead must be securely fastened with minimum of grade 5 bolts minimum of 3/8 inch.
All bolts must be doubled nutted or safety wired. Locking nut alone is not legal.
All "single bolt mount" clamps must have duct tape or pinned at bolt to keep lead from backing off.
25 lbs per bolt mount. One bolt 25 pounds, two bolts 50 pounds. No one piece over 50lbs.
Jig chassis allowed.
Clip chassis allowed.
No underbody shields allowed.
Engine setback 25 1/2 inches. Measured from center of ball joint to front of engine plate.

RADIOS

Radios ARE NOT legal at any time.

Raceceivers mandatory at touring events.

Raceceivers must be in working order at all times.

Should there be an issue with your receiver during an event, pull down and advise race official.

CONDUCT RULES

Any driver or crew member that puts their foot on the race track without the assistance of a Series Official will be disqualified immediately. No points awarded. No starting money. This does not include fire or safety instances.

Any person fighting will be fined \$500 for first offense, \$1000 for second offense, and third offense \$5000.

That car will not race again until fine has been paid in full. No points or money awarded for that event.

Unsportsmanlike conduct will not be tolerated on or off track while attending an event.

Any driver that is black flagged and does not adhere to flag will be fined \$500.00. No points awarded. No starting money.

If you spin someone out and it is seen as *intentional* by Officials, you will go to the rear the first time and be disqualified the second time.

If Series Official sees it as intentionally spinning someone, spun competitor **may** be allowed to go back to position.

Two unassisted spins and you are out for the night. 3 spins will be allowed if you are involved with other cars.

Pulling hoods or anything that constitutes actual race performance will be considered stopping on the track and result in going to the rear!!!!

Internet bashing or defamation may result in membership being 'revoked' and/or fined \$500.

ANY person "touching" an Official at ANYTIME will be disqualified. Loss of points and monies for that event. \$500 fine.

Drivers are responsible for ALL persons within their team.

DECAL PACKAGES

Decal packages mandatory. Series will furnish decals and designated positions per diagrams provided in member packets. Series reserves the right to display sponsor decals on front fenders of each competitor's car at a FASTRAK event. FASTRAK reserves the right to 10 'specified positions' on each competitor's car, *members or not*.

*No decals, no points. Also will not be eligible for contingencies and other monies from sponsors.

Event Partners: Event Partners are one time partners for that event only. Please feel free to remove decals after the event.

INDIVIDUAL TRACK RULES

Note that track rules on an individual basis may over ride series rules. This is in relation to mufflers, safety items, etc. such as window nets, gloves, etc. Please check with the individual track before attending an event.

DISCLOSURE STATEMENT

**Disclaimer

PLEASE READ CAREFULLY. YOU ARE ENTERING INTO A LEGAL AGREEMENT BY COMPETING AT A FASTRAK EVENT.

By participating in a FASTRAK event, participant(s) is entering into a legal agreement with FASTRAK Companies International LLC/ DBA FASTRAK Racing Series, to be later referred to as SERIES. In addition person(s) participating is also entering into a 'HOLD HARMLESS' contract with above mentioned companies, officers of said companies, sponsors, employees, officers, stock holders, Regional Directors (in good standing) and weekly sanctioned tracks (in good standing). Participant(s) agrees that racing is a dangerous sport and is hereby forfeiting any and all legal rights against all previously mentioned parties for any reason *whatsoever*. Participant(s) also agrees that SERIES may confiscate all parts should person signing be found "illegal". Driver and car owner AGREE that by participating in a FASTRAK weekly or touring event, should competitor be found *illegal*, all rules and penalties stated within FASTRAK RULE BOOK and *penalty* section of FASTRAK RULE BOOK TAKE FULL PRECEDENCE OVER ANY UNDERSTANDING 'IMPLIED OR OTHERWISE'. SERIES reserves the right to "decline" any membership. Series MAY ALSO CANCEL ANY MEMBERSHIP without notice. Participant and parties with said participant(s), understands they are "willingly" agreeing to all terms of this contract and hereby forfeit any and all legal rights of any type INCLUDING BUT NOT LIMITED TO "DEFAMATION OF CHARACTER". Participating in an event constitutes a contract.

FASTRAK cannot be held responsible for accidents.

FASTRAK Racing Series Body and Spoiler Specification Illustrations

Copyright 2010 FASTRAK Companies International LLC

604 Spoiler/Side Blades

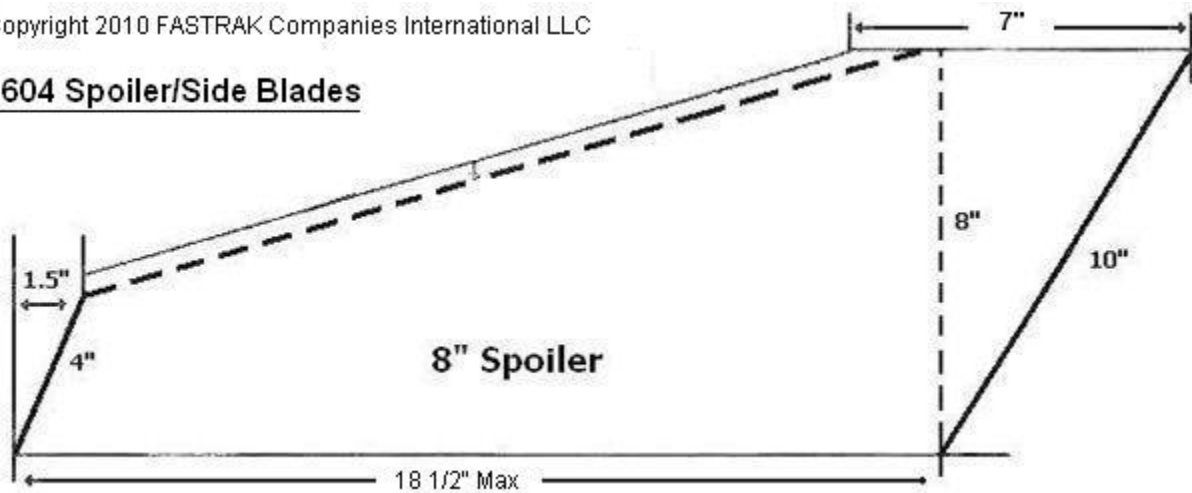

Copyright 2010 FASTRAK Companies International LLC

602 Spoiler /Side Blades

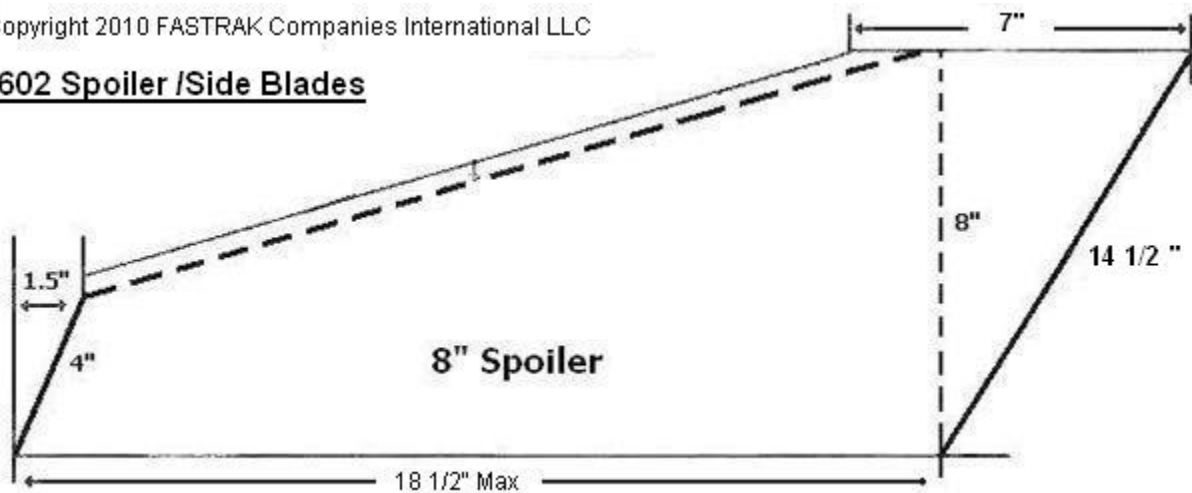

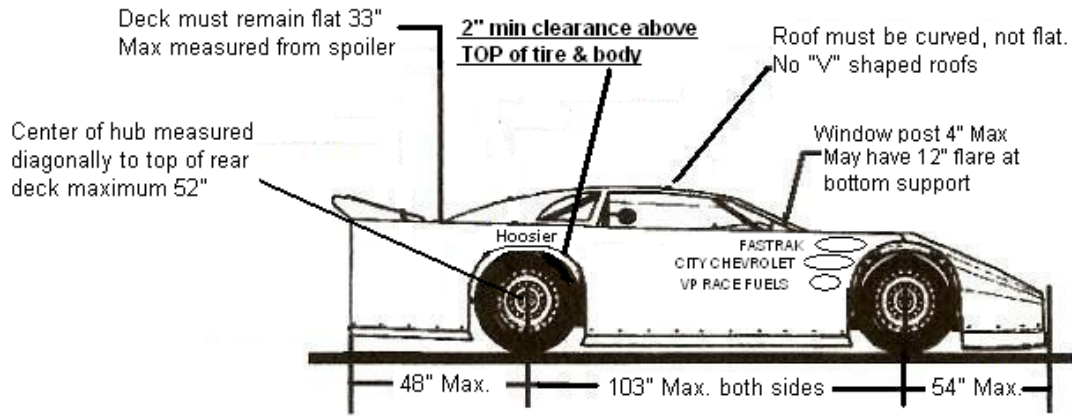

FASTRAK, Hoosier, GM, City Chevrolet, & VP Racing Fuels in specified locations is MANDATORY

